

SYSTEMATIC PROCESS FOR CONSTRUCTING SPHERICAL FOUR-BAR MECHANISMS

Michael L. Turner[†]
michael.turner@notes.udayton.edu

David A. Perkins[†]
perkindz@notes.udayton.edu

Andrew P. Murray[†]
andrew.murray@notes.udayton.edu

Pierre M. Larochelle[‡]
pierrel@fit.edu

[†]University of Dayton

[‡]Florida Institute of Technology

ABSTRACT

This paper presents a methodology for constructing spherical four-bar mechanisms with an emphasis on utilizing simpler machining processes and part geometries. By building each link out of easily created pieces instead of a single complex shape, a mechanism can be quickly prototyped and tested. The paper discusses the benefits and some of the issues that need to be addressed by this approach. Significant areas of concern include link design and tolerancing issues.

INTRODUCTION

One of the principal challenges in constructing working prototypes of spatial mechanisms is the large amount of custom design and machining for each individual assembly. We are building multiple testable prototypes in pursuit of automated assembly uses for low degree-of-freedom spatial mechanisms, with particular interest in the spherical four-bar. The tests are intended to compare actual performance and control methods to theoretical values [2][3][10]. As a result, we have developed a method for economically and quickly constructing a spherical four-bar.

This method will build a mechanism with the interior angles and initial joint axes that define the kinematics. It is assumed that the particular angle and axes have been determined by a separate synthesis method. From the initial data, a procedure is followed which produces mechanical drawings based on standardized elements. The elements are designed for ease of manufacture on a standard 2-axis mill, even without CNC capabilities.

The final product is a functional spherical four-bar mechanism. The mechanism has a smooth motion profile with

rigid links, allowing it to be used for testing dynamic performance and controller performance.

BACKGROUND

This work is part of a larger effort to develop low degree-of-freedom mechanisms capable of performing spatial assembly tasks that would otherwise be completed by a robot. Ruth and McCarthy [9] demonstrated the versatility of a spherical four-bar (s4R) by showing that it can be used to move an object to four specified orientations. Tse and Larochelle [11] showed how spherical mechanisms may be used to solve spherical approximations of general spatial tasks. Larochelle et

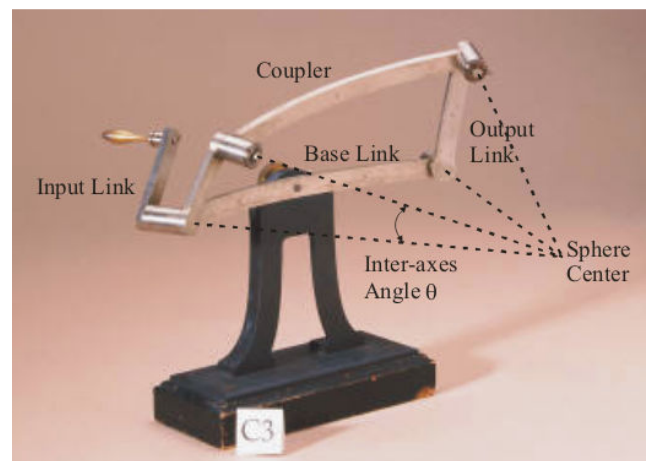

Picture © Cornell University and John Reis

Figure 1: A Spherical Four-Bar (s4R)

al. [7] created a software package for synthesis and analysis of the s4R mechanism for four desired orientations.

A typical methodology for designing an s4R used in rigid body guidance will produce 4 link angles and a coupler attachment location. The specific procedure we are using was presented by Perry et al. [8], in which an s4R with a prismatic sliding base capable of performing a pick-and-place operation between two specified poses in space was designed. (Pose is defined as a displacement and rotation from a reference coordinate system.) As shown in Figure 2, the part is initially in pose 1 and is moved to pose 2. The two poses are defined in terms of a fixed reference frame, F , by the rotations, A_i , and displacements, d_i . Since the part likely begins and ends its motion in contact with other elements, such as conveyor belts or mating parts, initial and final trajectory constraints, t_i , are placed on the motion to prevent collisions. The synthesis process by Perry calculates the direction of travel for the prismatic joint and the interior angles for the s4R.

The s4R mechanism is a single degree-of-freedom mechanism analogous to the planar four-bar. The mechanism consists of four rigid links connected by rotational (R) joints whose axes intersect at a common point, as shown in the mechanism from the Rouleaux collection at Cornell University (Figure 1). The kinematic behavior of the mechanism, such as joint range of motion, is determined by the angles between the joint axes. [1]

Since all of the rotational axes intersect at a single point, any point on the mechanism will stay a constant radial distance from the intersection point as the mechanism moves, effectively tracing out a curve on the surface of a sphere. We refer to the axes intersection point as the sphere center.

A point on the coupler will trace out a sixth order curve on the surface of the sphere. The high order curve is what allows the synthesis to find an s4R capable of meeting the reorientation and trajectory specifications of the pick-and-place task. The part is grasped by an end-effector connected to the coupler such that the gripping point has the desired motion properties.

An automated process for creating machining specifications for an s4R was first addressed by Ketchel and Larochelle [5]. Their automated process, SphinxCAM, takes the angles between the joint axes as the input and produces an AutoCAD drawing of four curved links. The drawing can be sent to a CAM program for cutting the links out of a single plate. The work in this paper leverages much of the knowledge presented by Ketchel and Larochelle, though we propose a different methodology.

MODULAR CONSTRUCTION METHODS

The links of the s4R must be rigid elements with bearings at either end in which the axes of the bearings intersect at a specified angle. The intervening structure between the bearings can be any shape, provided it is sufficiently rigid to carry the load. The size of the link can be selected by the designer without changing the theoretical motion of the mechanism.

The typical method of achieving this structure has been to mill the link out of a solid plate of metal. This has the benefits of being straightforward to design and allowing the curvature of

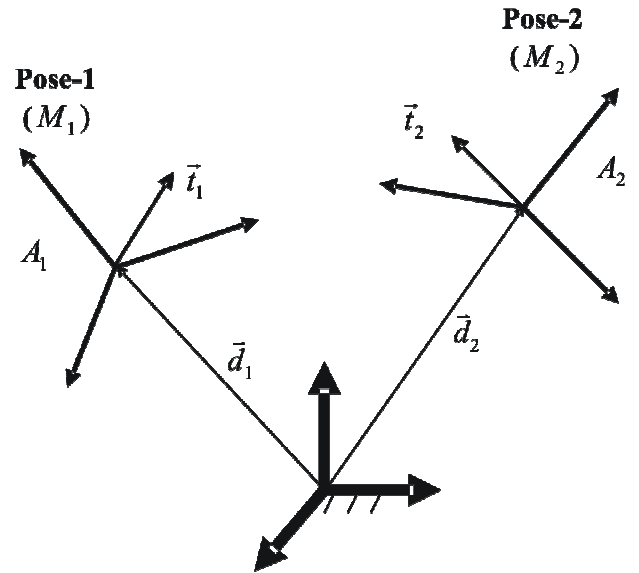

Figure 2: Two Pose with Trajectory Pick-and-Place Problem

the link to match the radius from the center of the sphere. This method has the drawbacks of using significant amounts of material, requiring complex CNC path programming and presenting part fixturing difficulties.

Our methodology constructs the links from several smaller and more easily machined pieces. This idea was inspired by the realization that TinkerToys™ would build quick s4Rs if they allowed angular connections at arbitrary angles instead of increments of 45°. (Figure 3B)

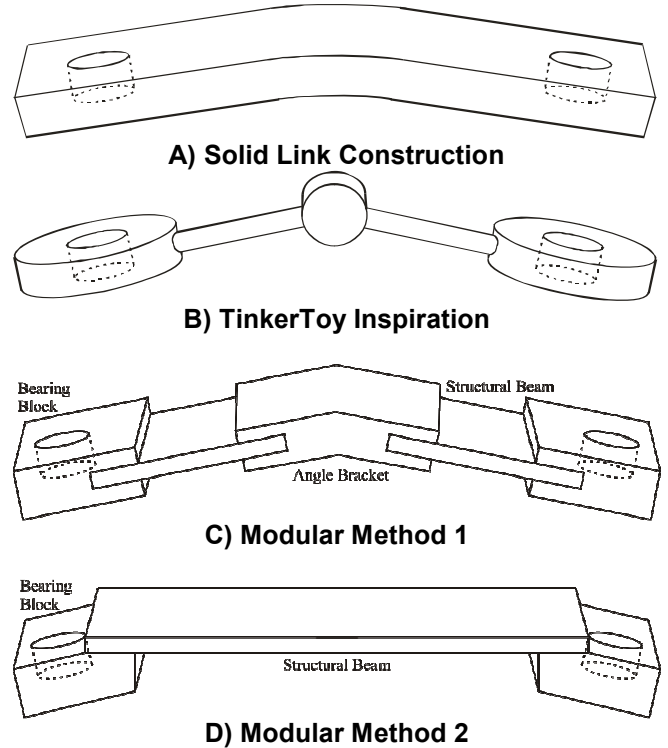

Figure 3: Alternate Methods of Constructing Links



Figure 4: Constructed Modular Prototype Method 1

The first modular construction concept (Figure 3C) consisted of rectilinear bearing blocks at either end, which would be standard on all links. In the center is the angled block, which is cut to the specifications of the link angle. Since the link angle can be any value from 0° to 180° , the center block requires specialized machining, such as a programmed CNC mill. The bearing blocks are connected to the angled block with structural beams cut to length.

The bearing blocks are machined from bar stock with very little wasted material. In addition, the block can be reused for a new s4R design. The structural beams are made from 0.25” bar stock and cut to length. They can be reused in a new s4R design for beams of the same or shorter length. The central angled block is cut out of a plate of metal using similar methods as the solid link process, but requiring significantly less material. The connections between the structural beams and the blocks are a “snug” fit secured by shoulder bolts.

A prototype constructed using this methodology is shown in Figure 4. This prototype does move and follows the desired motion; however it did show some room for improvement. The most noticeable insight is the high “elbow” of the output link. This is caused by a relatively large angle between the joint axes for this link ($\sim 73^\circ$). The high elbow means that the distance from the center of the sphere to the nearest point on the link and the distance from the center of the sphere to the furthest point on the link are significantly different, which complicates the process of preventing link interference discussed later in this paper.

The second modular construction concept (Figure 3D) consists of two bearing blocks connected by a single structural beam. In this concept, the bearing blocks are custom machined blocks with a flat surface at the necessary angle to which the structural beam is attached. Depending upon machine availability and desired tolerance, the angled face can be machined with a 2 axis CNC mill, a standard mill using a sine bar to hold the angle or an adjustable angle vise. We recommend machining a second face perpendicular to the first one to make drilling the connection holes easier. The prototype



Figure 5: Constructed Modular Prototype Method 2

constructed by this method, shown in Figure 5, does not have the elbow issue of the first mechanism.

While the specific angle between the beam attachment face and the bearing shaft means these blocks are not likely to be reused in future s4R designs, new ones can be easily machined out of bar stock with little waste material.

CONSTRUCTION PROCESS

The process of creating part drawings for machining begins with determining how far each link is from the spherical center. The simplest way to avoid collisions between the links is to place each one at a different distance from the spherical center. If the nearest point on the coupler is further from the spherical center than the furthest point on the output link, the two links will not collide. (There is still the opportunity for a link to collide with a joint axis connecting two other links. For the link designs presented here this will only occur near a singular configuration. If the designer intends the mechanism to operate near the singularity, other accommodations need to be made.)

The links are laid out with each one having its own orbit range around the spherical center, as shown in Figure 6. The

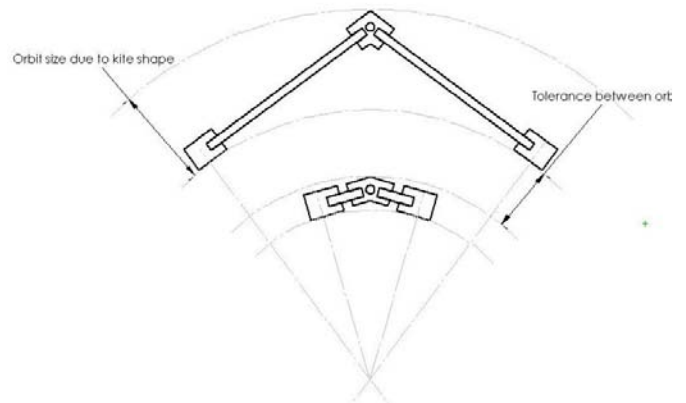

Figure 6: Non-interfering Link Orbits

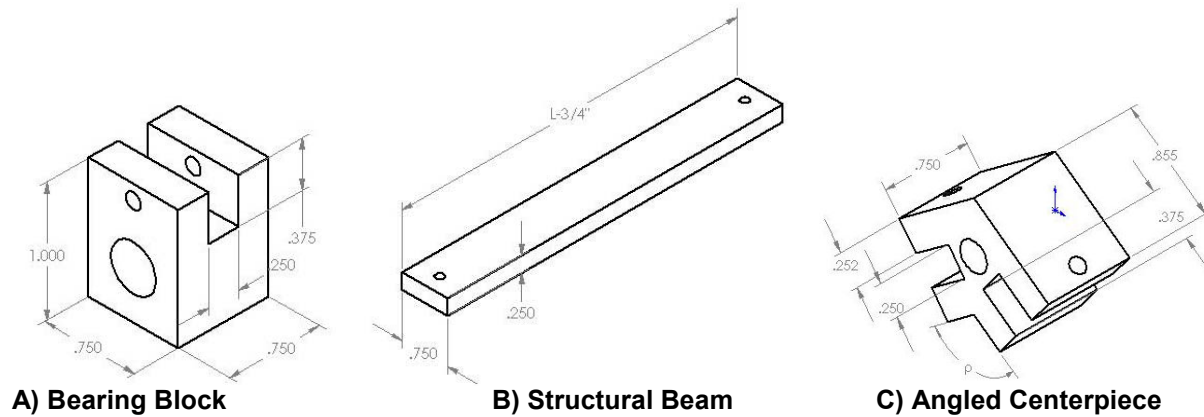

Figure 7: Machining Drawings for Modular Method 1

links are typically laid out with the fixed link having the closest orbit range, followed by the input link, then the output link and finally the coupler. The coupler has the furthest orbit, because it allows the end-effector to be connected to it without creating additional collision issues.

It should be noted that keeping the links in separate orbits is sufficient to avoid link collisions, but it may not be necessary. s4Rs can be designed to have some overlap of link orbits without link collisions. For example, in the prototype shown in Figure 4, the coupler is placed at a significant distance from the output and input links due to the large orbit range of the output link. It could actually be moved inside the output link's orbit range without collision issues. A 3D CAD model can be used to see if overlapping orbits are acceptable for any particular mechanism before it is built.¹

The specific orbit ranges can be chosen arbitrarily, though some guidelines are appropriate. It is useful to have the workpoint of the end-effector lie in the orbit of the coupler, or slightly above it. This allows the end-effector to be connected to the coupler without extending into the orbits of the lower links. The axes between the links should be kept as short as possible, since this is the primary source of unwanted flexure in the mechanism.

If R is the distance from the sphere center to the middle of the bearing block for a link with an interior joint angle of θ , then the orbit range for a link built by method 1 would go from R to $R \sec(\frac{\theta}{2})$. Similarly, for the second modular

construction method the orbit range would go from $R \cos(\frac{\theta}{2})$

to R . Part of the advantage of the second method is that the size of the orbit is smaller for all applicable values of θ , though the range can still be relatively wide for large values of θ . (A possible solution may be to extend the bearing blocks for large angle links, creating a trapezoid which approximates

the radial curve.) The designer, using the guidelines presented above, can pick the values of R for each of the links and make sure the orbits do not overlap.

In the first modular construction method, the link geometry forms the kite shape shown in Figure 8. The two terms that need to be calculated are L , the length between the joint axis and the center of the angled block, and ρ , the angle between the structural beams. The calculations are:

$$L = R \tan\left(\frac{\theta}{2}\right)$$

$$\rho = \pi - \theta$$

The two bearing blocks, two structural beams and central angle piece are machined according the drawings shown in Figure 7. The bearing holes in the bearing blocks are currently sized to hold sleeve bearings with collars on the axles to

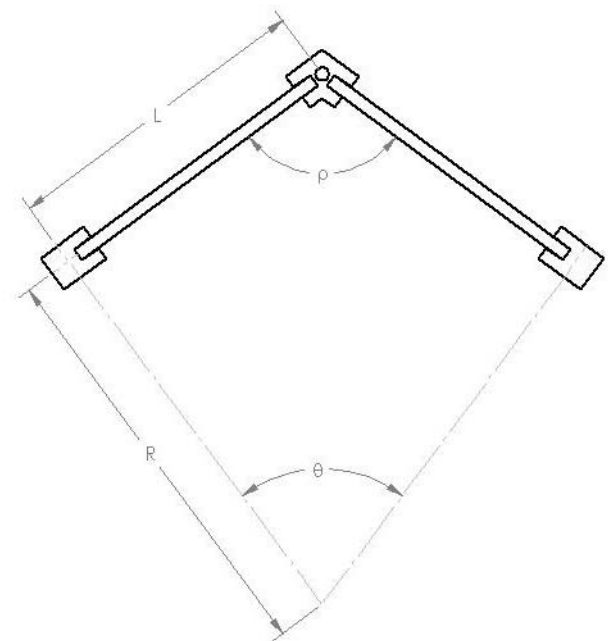

Figure 8: First Modular Design Variables

¹ Most CAD packages are not well suited to model the kinematics of an s4R mechanism. For example, it is usually necessary to leave one of the joints as a cylindrical joint to allow the mechanism to move. Other non-desirable behaviors are also common. A software interface specifically designed for the s4R is preferable. [4]

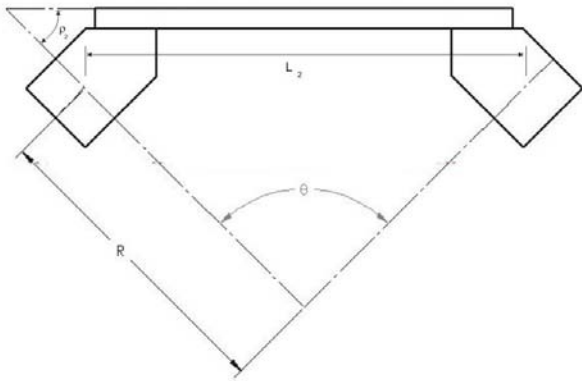

Figure 9: Second Modular Design Variables

prevent axial slip. Future constructions will use roller bearings to reduce friction.

One of the bearing blocks on the base link needs to be machined to connect with the motor housing. The motor is mounted on the base link and then connects to the input axle. The bearing block on the input link which houses the input axle is designed without a bearing, since the input axle needs to be rigidly attached to it in order to transmit the motor torque.

When assembling the mechanism, the input axle and motor are the last parts to be connected. Since it is impossible to slide a rigid link down two non-parallel axles, it is necessary to assemble the mechanism and line up the shaft holes on the input link and the base. The input axle is slid through the oversized hole on the base link and attached to the input link. The motor shaft is then connected to the input axle. Finally, the housing of the motor is connected to the base.

In the second modular construction method, the link geometry forms a triangle as shown in Figure 9. The two terms that need to be calculated are L_2 , the length between the centers of the bearing blocks, and ρ_2 , the angle between the structural beam and the axle. The calculations are:

$$L_2 = 2R \sin\left(\frac{\theta}{2}\right)$$

$$\rho_2 = \frac{\pi - \theta}{2}$$

The two bearing blocks and the structural beam are machined according to the parts drawing in Figure 10. The motor is connected to the base link similarly to method 1.

COMPARISON OF METHODS

In this section, the machining procedures for the three construction methods (solid link, modular concept 1 and modular concept 2) are compared. Four different link sizes are considered, based on the arc length between the centers of the two shaft holes at the ends of the link. The four lengths are 3", 6", 8" and 10". The curvature of the link only has a secondary effect on costs, and so for the purposes of clarity is neglected in this discussion.

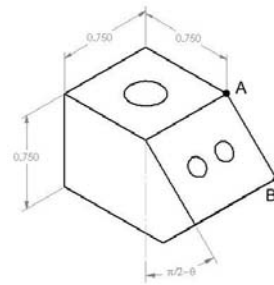

A) Bearing Block

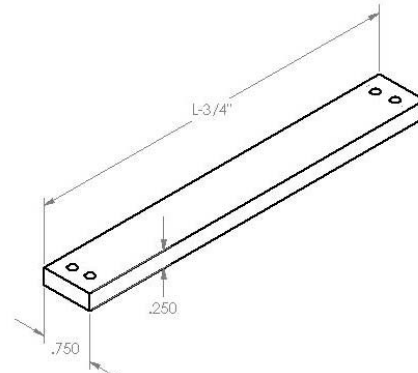

B) Structural Beam

Figure 10: Machining Drawings for Modular Method 2

In comparing these methods, some basic assumptions have been made. The material costs are based on 6061 aluminum at the prices listed by McMaster-Carr. The machining times are based on the estimate that it requires two passes with a mill to cut through aluminum at depths of 0.50" to 1", but all passes are performed at the same feedrate. It is also presumed that finishing passes with the end-mill to bring all the dimensions into tolerance are equivalent for the three methods.

The solid link milled out of aluminum plate is 0.75" wide, 0.75" deep (the nominal thickness of the plate) and 4, 7, 11 or 13 inches long (a half inch is added to the ends of each link to allow for bearing placement). Machining a complex shape out of a plate produces a lot of waste material, even if care is taken to lay out multiple links well. As a conservative estimate, we consider that an amount of aluminum equal to the size of the link is wasted.² The 3" link requires 6 in² in aluminum at a cost of \$3.08, with a machining surface of 19 inches (two passes around the 9.5" perimeter). Similarly, the 6" link costs \$5.39 and has a machining surface of 31". The 10" link costs \$8.48 in material with a machining surface of 47". The 12" link costs \$10.02 with a machining surface of 55".

The first modular construction method uses standardized bearing blocks milled to a length of 1" from nominal 0.75" by 0.75" bar stock with a 0.375" deep slot for structural beam. The material cost for each is \$0.36 with a machining surface of 4.5". (Two passes to cut the face and the notch.) The center angular block is 1" long, 0.75" wide and milled from the same aluminum plate as the solid link and uses the same assumption for wasted material. It costs \$0.77 with a machining surface of 8.5". The structural beams are milled from 0.25" by 0.75" bar

² It is possible to use a Wire EDM machine to cut the links from the aluminum plate with less waste material. However, these machines are not as common as 2-axis CNC mills.

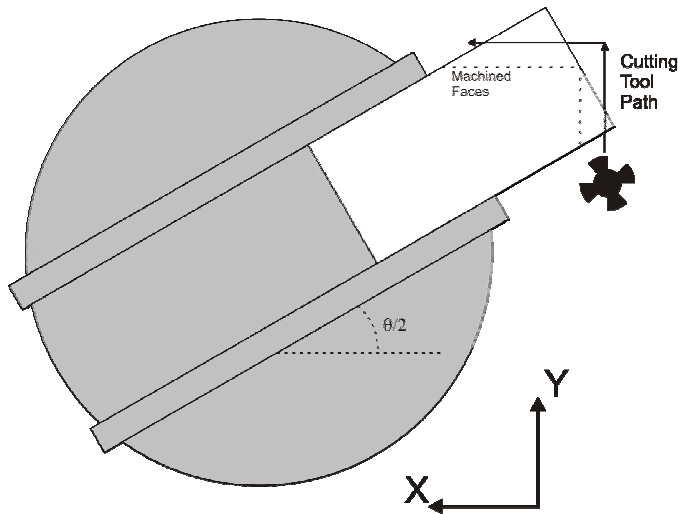

A: Milling the angle faces

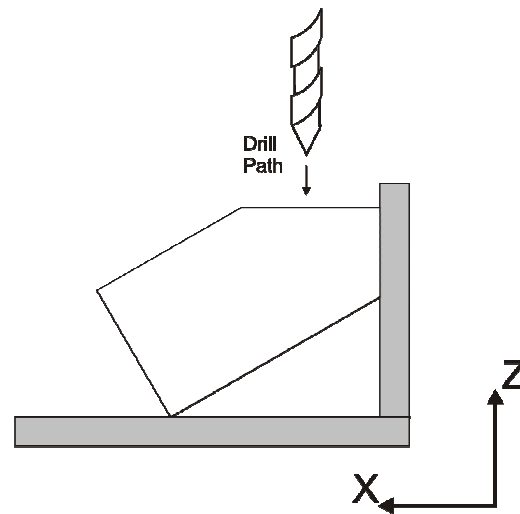

B: Drilling attachment holes

Figure 11: Machining the bearing block without CNC machining

stock and have a machining surface of 1.5” each. The only cost that varies with the length of the link is the material cost of the structural beams which is \$0.28, \$0.70, \$1.25 and \$1.53 for prescribed link lengths.

The second modular construction method uses bearing blocks from 0.75” by 0.75” bar stock with a length of up to 1.5”. The material cost of each bearing block is \$0.71 with a machining surface of up to 3”. The single structural beam has a machining surface of 1.5” and a material cost of 0.35, 0.76, 1.32 and 1.60 for the prescribed link lengths.

These results are summarized in Table 1.

The benefits of the first modular construction process are not as prevalent for the smallest link, since the machining effort is identical. It is for this reason that the prototype shown in Figure 4 has solid links for the small base and coupler links. For the larger links, the savings in cost and machining time become significant.

The second modular concept is the most advantageous at all sizes in terms of machine cutting time and material costs. The benefits of the modular construction are increased if the construction material is changed to steel, since it would likely take four passes with the mill to cut through 0.75” plate.

It is a machinist’s axiom that securing a part for machining is 90% of the work. Fixturing issues are almost entirely eliminated in the second modular method by the use of small rectilinear pieces. The complex shapes cut out of plate for the solid link and first modular method can create challenging fixturing issues.

The second methodology can be more readily machined using a non-CNC mill than the other methods, as was done for the prototype shown in Figure 5. The bearing blocks start as 1” by 1” bar stock held in a parallel vice. The vice is rotated by $\theta/2$ with respect to the x-axis of the mill. (This rotation is currently done with a rotating vice and an accuracy of +/- 0.5°. We are working on a fixturing jig with a sine bar for increased accuracy.) As shown in Figure 11A, the two cuts in the bar stock can be made by making a pass in the y direction and a pass in the x direction. Figure 11B shows how the second face

on the bearing block makes it easier to fixture the part for drilling the screw holes on the attachment face.

Finally, the standardization of each part in the second methodology allows for some economies of scale in creating multiple versions of the same or similar parts. This is both in the increased familiarity of the machinist as well as the ability to create fixturing and localizing jigs for the parts.

The tolerance issues of the modular construction methods may be the most significant drawback in comparison to the solid link method. Because the solid link is cut in one session by a mill, the tolerance on the distance and angle between the axle holes depends only on the calibration of the mill. Tolerances less than ± 0.005 ” are relatively easy to obtain.

In the modular construction methods, the machining tolerances of the individual pieces are added to the tolerances of assembling the multiple pieces together. The tolerances for the individual pieces need to be kept to ± 0.001 ” in order to achieve ± 0.005 ” across the length of the link. The desired snug fit between the beam and the block on the first modular construction placed additional constraints on the tolerances, and contributed to development of the second modular method.

The method for creating the angled surface in the second method largely determines the tolerance. If a CNC mill is used and if point A at the top of the angled surface and point B at the bottom of the angled surface have a relative tolerance of ± 0.001 ” (see Figure 10A), the angle of the surface could vary by as much as 0.15°. If a sine bar is used, it is possible to achieve angular accuracy of ± 0.01 °. On the other hand, if an

Link Size	Solid		Concept 1		Concept 2	
	Materials	Machining	Materials	Machining	Materials	Machining
3"	\$3.08	19"	\$1.77	19"	\$1.77	4.5"
6"	\$5.39	31"	\$2.19	19"	\$2.18	4.5"
10"	\$8.48	47"	\$2.74	19"	\$2.74	4.5"
12"	\$10.02	55"	\$3.02	19"	\$3.02	4.5"

Table 1: Comparison of Construction Methods

accuracy of $\pm 0.5^\circ$ is acceptable, a rotating vise can be used and greatly simplify the machining process.

There have been no rigorous studies on the effect of machining tolerances on the performance of a spherical linkage, though Kim et al. [6] discuss a method for calculating changes in system dynamics.

Kinematic theory says that all four joint axes have to intersect precisely at a single point, but mechanisms built to date with typical machining tolerances have all moved as planned. This is analogous to the planar four bar, for which theory says all the axes must be exactly parallel but are regularly built with standard tolerances. The reasons for the assembly success rate became apparent when some poorly machined parts were connected.

As described previously, joint axles are slid through the bearing holes to assemble the mechanism. For a well constructed mechanism, the axles will slide to a specific point during assembly and will not slide during the mechanism motion. If there are errors in either L or θ on a link, the mechanism can still assemble with the joint axes intersecting, though the axles will slide to a different length producing a slightly different configuration.

If the axle shafts on a single link are not co-planar, then the axes will not intersect. In this case, the mechanism will not operate as an s4R but rather at least one of the rotation joints will act as a cylindrical joint, with the link sliding along the axle while rotating about it.

These observations show why constructing functional spherical mechanism appears to work so often. Errors in L or q still produce functional s4R mechanisms, though with position errors at the end effector. Errors in the planarity of the links cause the joints to act as cylindrical joints, and for small errors the cylindrical motion should be smaller than the mechanical "slop" in the joint. More rigorous, numerical analysis is currently being pursued.

One other concern of the modular construction methods is whether the link will remain sufficiently rigid under loading. Since bending stiffness largely scales quadratically with beam thickness, the 0.25" beam will deflect nine times further than the 0.75" solid link under the same load. However, the loads under which this mechanism is designed to operate will not produce significant deflection in the beam. Any load that would deflect the beam adversely would cause a far more detrimental deflection in the joint axes.

Rudimentary tests of driving the mechanism with a motor indicate that this can be a problematic method of moving the mechanism. In most configurations, a significant fraction of the input torque produces internal forces in the mechanism rather than an applied force at the end-effector. A more thorough analysis, as well as some possible alternatives will be presented in future work.

CONCLUSION

The modular construction method offers the designer of a spherical four-bar a means of building a functioning and testable prototype at lower cost and with easier machining than using solid link construction. We have demonstrated the viability of this approach using one modular construction method. The lessons which we learned from the first

prototype have been used to develop a second modular construction method for which a prototype is currently being constructed.

If the purpose of constructing a spherical four-bar is to build a single mechanism, the benefits of the modular construction method are minimized. In our research, we expect to build multiple designs and will take advantage of the cost and time savings.

The ability to quickly machine and assemble working spherical four-bars will allow us to perform tests on dynamic performance, control and machine precision in our pursuit of designing practical spatial mechanisms.

ACKNOWLEDGMENTS

This work was made possible in part by a grant from the National Science Foundation (DMI-0422731). Additional funding was provided by a University of Dayton Research Seed Grant.

REFERENCES

- [1] Chiang, C.H. Kinematics of Spherical Mechanisms, Cambridge University Press, New York, 1988.
- [2] Dooley, J.R., McCarthy, J.M., "Dynamic Analysis of a Spherical Four-Bar Mechanism", Flexible Mechanisms, Design and Analysis, ASME, New York, 1992.
- [3] Dooley, J.R., "Dynamic Force and Torque Analysis of a Spherical Four-Bar Mechanism." ASME Design Automation Conf., 1995
- [4] Furlong, T.J., Vance, J.M. and Larochele, P.M., "Spherical Mechanism Synthesis in Virtual Reality", Journal of Mechanical Design, Transactions of the ASME, vol. 121, no. 4, Dec 1999, p. 515-520.
- [5] Ketchel J.S. and Larochele, P.M., "SphinxCAM: Computer-Aided Manufacturing for Spherical Mechanisms", ASME Design Engineering Technical Conference, 1998.
- [6] Kim, H.W., Bae, D.S. and Choi, K.K., "Configuration Design Sensitivity Analysis of Dynamics for Constrained Mechanical Systems.", Computational Methods in Applied Mechanics and Engineering, vol. 190, 2001, pp. 5271-5282.
- [7] Larochele, P., Dooley, J., Murray, A.P. and McCarthy, J.M., "SPHINX, Software for Synthesizing Spherical 4R Mechanisms", Proceedings of the NSF Design and Manufacturing Systems Conference, University of North Carolina at Charlotte, NC, Jan 1993, pp. 607-611.
- [8] Perry, L.S., Turner, M.L. and Murray, A.P., "The Kinematic Synthesis of a Two Spatial Position, Two Velocity Problem Involving a Spherical Mechanism.", ASME Design Engineering Technical Conference, vol. 5, 2002, pp. 1011-1017.
- [9] Ruth, D.A. and McCarthy, J.M., "Design of Spherical 4R Linkages for Four Specified Orientations." Mechanism and Machine Theory, vol. 34, no. 5, 1999, p. 677-692
- [10] Shome, S.S., Beale, D.G. and Wang, D. "A General Method for Estimating Dynamic Parameters of Spatial Mechanisms", Nonlinear Dynamics, vol. 16, pp. 349-368, 1998
- [11] Tse, D. and Larochele, P., "On Realizing Spatial Motions with Spherical Mechanisms", Proc. of the 1998 Florida Conference on Recent Advances in Robotics, Melbourne, Florida, March 26-27, 1998, pp.39-47